



Infrastructure Health
& Safety Association™
A Health & Safety Ontario Partner

Trenching Safety



TRENCHING SAFETY

INTRODUCTION TO TRENCHING HAZARDS

Infrastructure Health & Safety Association

5110 Creebank Road, Suite 400, Mississauga, Ontario L4W 0A1 Canada
1-800-263-5024 www.ihsa.ca



The contents contained in this publication are for general information only. This publication should not be regarded or relied upon as a definitive guide to government regulations or to safety practices and procedures. The contents of this publication were, to the best of our knowledge, current at the time of printing. However, no representations of any kind are made with regard to the accuracy, completeness, or sufficiency of the contents. The appropriate regulations and statutes should be consulted. Readers should not act on the information contained herein without seeking specific independent legal advice on their specific circumstance. The Infrastructure Health & Safety Association is pleased to answer individual requests for counselling and advice.

© Infrastructure Health & Safety Association, 1991

All rights reserved. This publication may not be reproduced, in whole or in part, or stored in any material form, without the express written permission of the copyright owner.

Revised, December 2007

Revised, January 2009

Revised, November 2010

ISBN-13: 978-0-919465-50-3

Contents

- Background
- Soil types
- Causes of cave-ins
- Protection against cave-ins
- Other hazards and safeguards
- Emergency procedures
- Appendix A: The “Excavations” part of the Construction Regulation (O. Reg. 213/91)
- Review Quiz

Background

Fatalities

A significant number of deaths and injuries in sewer and watermain work are directly related to trenching.

Trenching fatalities are mainly caused by cave-ins. Death occurs by suffocation or crushing when a worker is buried by falling soil.

Over half of all powerline contacts involve buried cable. Before excavating, the gas, electrical, and other services in the area must be accurately located and marked. If the service poses a hazard, it must be shut off and disconnected.

Injuries

The following are the main causes of lost-time injuries in the sewer and watermain industry:

- materials and equipment falling into the trench
- slips and falls as workers climb on and off equipment
- unloading pipe
- handling and placing frames and covers for manholes and catch basins
- handling and placing pipe and other materials
- being struck by moving equipment

- falls as workers climb in or out of an excavation
- falling over equipment or excavated material
- falling into the trench
- exposure to toxic, irritating, or flammable gases.

Many of these injuries are directly related to trenching.

Regulations

Supervisors and workers in the sewer and watermain industry must be familiar with the “Excavations” section of the Construction Regulation, reprinted in Appendix A of this manual.

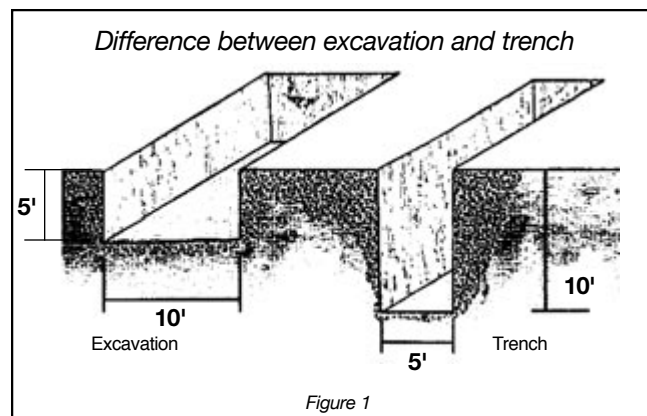

It is important to understand, for instance, the terms “trench” and “excavation.” An excavation is a hole left in the ground as the result of removing material. A trench is an excavation in which the depth exceeds the width (Figure 1).

The “Excavations” section of the Construction Regulation identifies the various types of soils and specifies the type of shoring and timbering to be used for each. It also spells out the requirements for trench support systems that must be designed by a professional engineer.

Soil types

The type of soil determines the strength and stability of trench walls.

Identifying soil types requires knowledge, skill, and experience. Even hard soil may contain faults in seams or layers that make it unstable when excavated.

The foreman or supervisor must be knowledgeable about soil types found on a project and plan protection accordingly. This knowledge must include an awareness that soil types and conditions can change over very short distances. It is not unusual for soil to change completely within 50 metres or for soil to become saturated with moisture over even smaller distances.

The Construction Regulation sets out four soil types. If you are unsure about the soil type, have the soil tested to confirm the type.

Type 1 — It is hard to drive a pick into Type 1 soil. Hence, it is often described as “hard ground to dig”. In fact, the material is so hard, it is close to rock.

When excavated, the sides of the excavation appear smooth and shiny. The sides will remain vertical with no water released from the trench wall.

If exposed to sunlight for several days, the walls of Type 1 soil will lose their shiny appearance but remain intact without cracking and crumbling.

If exposed to rain or wet weather, Type 1 soil may break down along the edges of the excavation.

Typical Type 1 soils include “hardpan,” consolidated clay, and some glacial tills.

Type 2 — A pick can be driven into Type 2 soil relatively easily. It can easily be excavated by a backhoe or hand-excavated with some difficulty.

In Type 2 soil, the sides of a trench will remain vertical for a short period of time (perhaps several hours) with no apparent tension cracks. However, if the walls are left exposed to air and sunlight, tension cracks will appear as the soil starts to dry. The soil will begin cracking and splaying into the trench.

Typical Type 2 soils are silty clay and less dense tills.

Type 3 — Much of the Type 3 soil encountered in construction is previously excavated material. Type 3 soil can be excavated without difficulty using a hydraulic backhoe.

When dry, Type 3 soil will flow through fingers and form a conical pile on the ground. Dry Type 3 soil will not stand vertically and the sides of the excavation will cave in to a natural slope of about 1 to 1 depending on moisture.

Wet Type 3 soil will yield water when vibrated by hand. When wet, this soil will stand vertically for a short period. It dries quickly, however, with the vibration during excavation causing chunks or solid slabs to slide into the trench.

All backfilled or previously disturbed material should be treated as Type 3. Other typical Type 3 soil includes sand, granular materials, and silty or wet clays.

Type 4 — Type 4 soil can be excavated with no difficulty using a hydraulic backhoe. The material will flow very easily and must be supported and contained to be excavated to any significant depth.

With its high moisture content, Type 4 soil is very sensitive to vibration and other disturbances which cause the material to flow.

Typical Type 4 material includes muskeg or other organic deposits with high moisture content, quicksand, silty clays with high moisture content, and leta clays. Leta clays are very sensitive to disturbance of any kind.

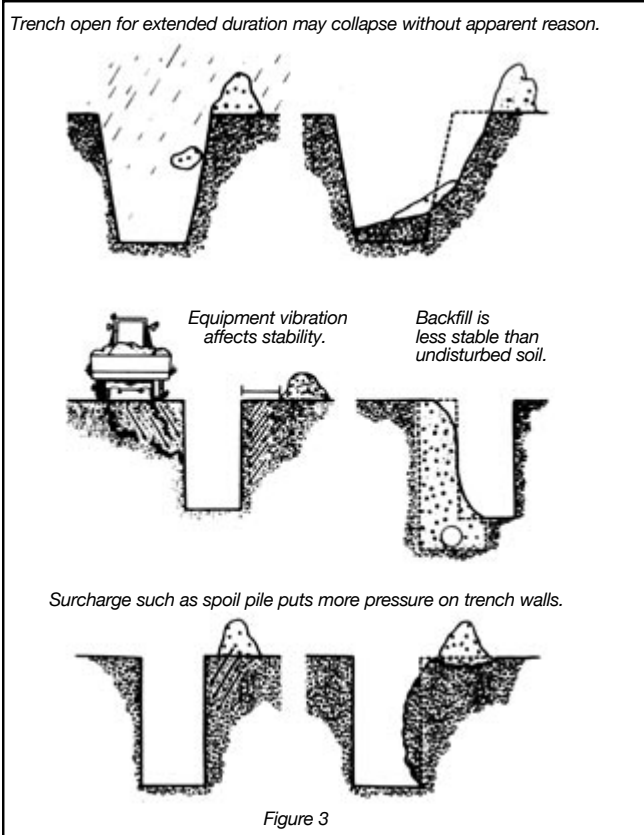

Many factors such as cracks, water, vibration, weather, and previous excavation can affect trench stability (Figure 2). Time is also a critical factor. Some trenches will remain open for a long period, then suddenly collapse for no apparent reason.

Figure 3 shows the typical causes of cave-ins.

The main factors affecting trench stability are soil type, moisture, vibration, surcharge, previous excavation, existing foundations, and weather.

Moisture content

The amount of moisture in the soil has a great effect on soil strength.

Once a trench is dug, the sides of the open excavation are exposed to the air. Moisture content of the soil begins to change almost immediately and the strength of the walls may be affected.

The longer an excavation is open to the air, the greater the risk of a cave-in.

Causes of Cave-Ins

Soil properties often vary widely from the top to the bottom and along the length of a trench.

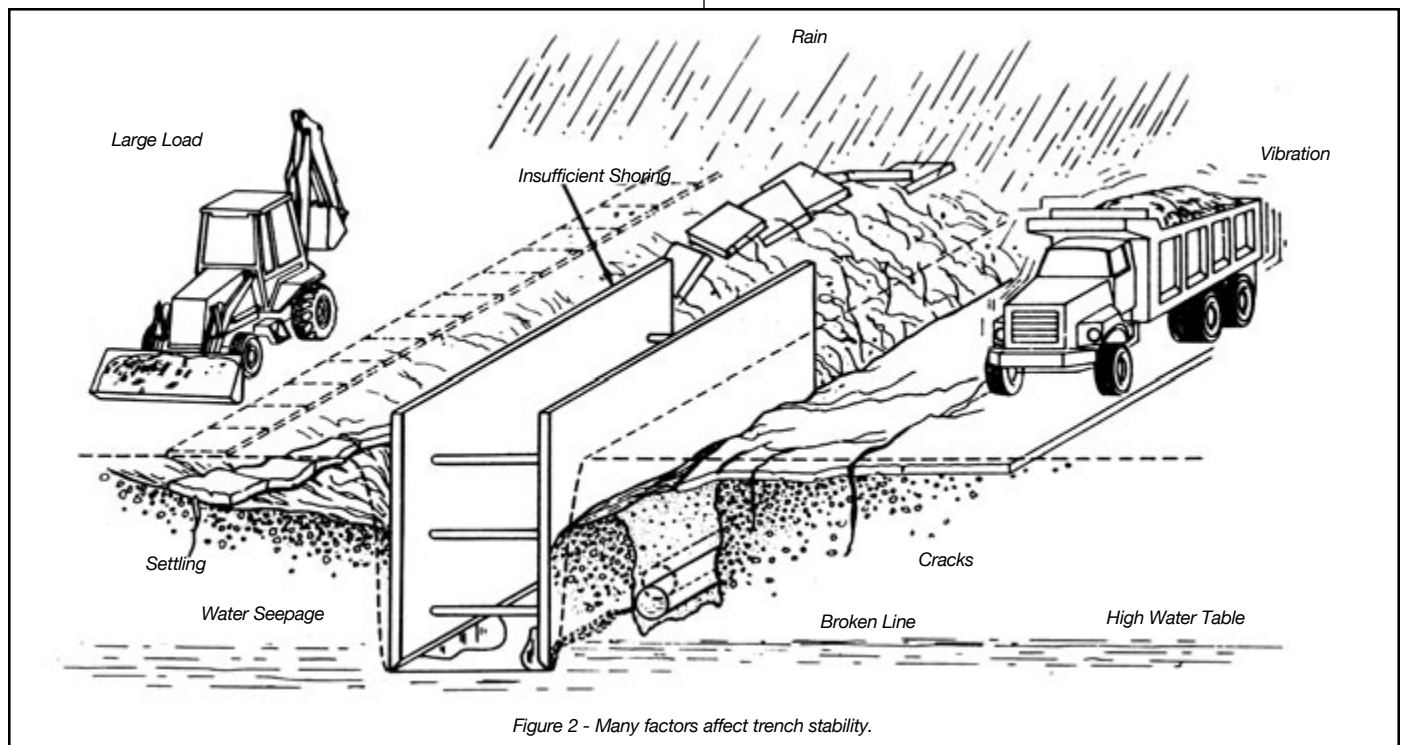

Vibration

Vibration from various sources can affect trench stability.

Often trench walls are subject to vibration from vehicular traffic or from construction operations such as earth moving, compaction, pile driving, and blasting. These can all contribute to the collapse of trench walls.

Surcharge

A surcharge is an excessive load or weight that can affect trench stability.

For instance, excavated soil piled next to the trench can exert pressure on the walls. Placement of spoil piles is therefore important. Spoil should be kept as far as is practical from the edge of the trench. Mobile equipment and other material stored close to the trench also add a surcharge that will affect trench stability.

One metre from the edge to the toe of the spoil pile is the minimum distance requirement (Figure 4). The distance should be greater for deeper trenches.

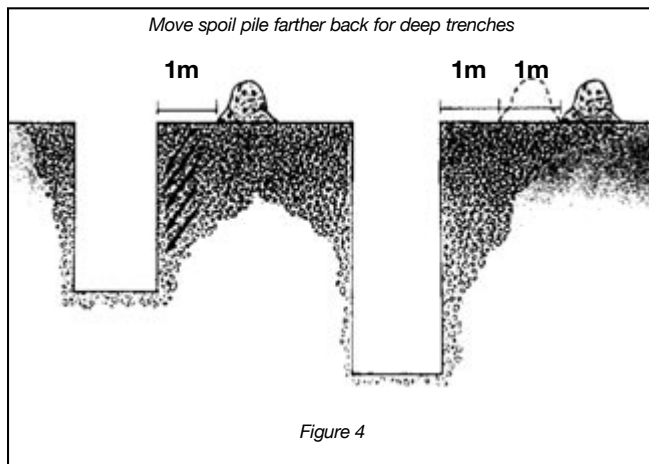

Previous excavation

Old utility trenches either crossing or running parallel to the new trench can affect the strength and stability (Figure 5).

Soil around and between these old excavations can be very unstable. At best it is considered Type 3 soil — loose, soft, and low in internal

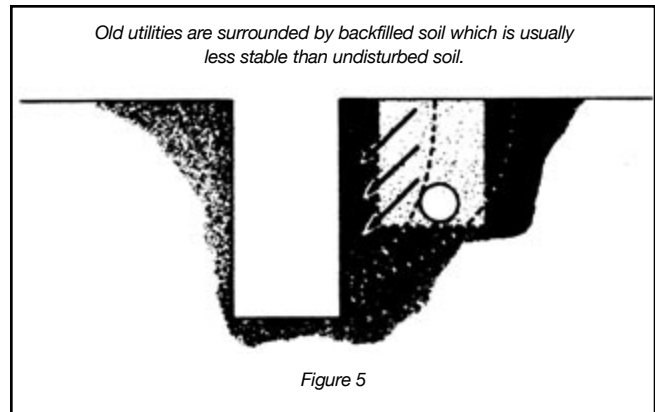

strength. In some unusual circumstances it may be Type 4 — wet, muddy, and unable to support itself.

This kind of soil will not stand up unless it is sloped or shored.

Existing foundations

Around most trenches and excavations there is a failure zone where surcharges, changes in soil condition, or other disruptions can cause collapse.

When the foundation of a building adjacent to the trench or excavation extends into this failure zone, the result can be a cave-in (Figure 6). Soil in this situation is usually considered Type 3.

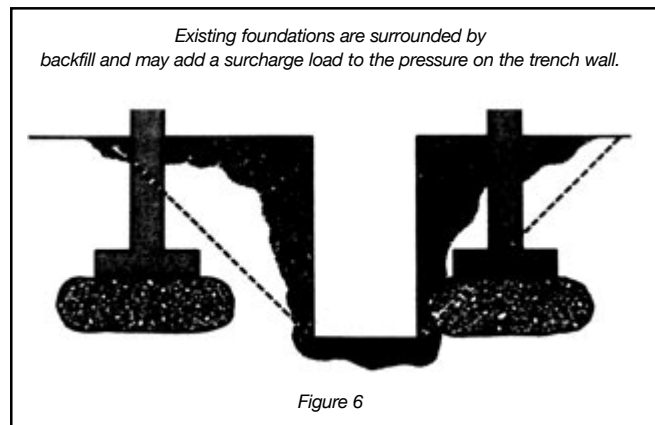

Weather

Rain, melting snow, thawing earth, and overflow from adjacent streams, storm drains, and sewers all produce changes in soil conditions. In fact, water from any source can reduce soil cohesion (Figure 7).

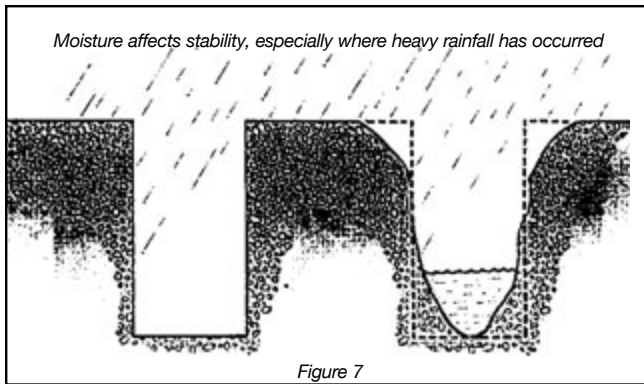

Frozen soil does not mean that you can have reduced shoring or that a heavier load can be supported. Frost extends to a limited depth only.

Protection Against Cave-Ins

There are three basic methods of protecting workers against trench cave-ins:

- sloping
- trench boxes
- shoring

Most fatal cave-ins occur on small jobs of short duration such as service connections and excavations for drains and wells. Too often people think that these jobs are not hazardous enough to require safeguards against collapse.

Unless the walls are solid rock, never enter a trench deeper than 1.2 metres (4 feet) if it is not properly sloped, shored, or protected by a trench box.

Sloping

One way to ensure that a trench will not collapse is to slope the walls.

Where space and other requirements permit sloping, the angle of slope depends on soil conditions (Figures 8, 9 and 10).

For Type 1 and 2 soils, cut trench walls back at an angle of 1 to 1 (45 degrees). That's one metre back for each metre up. Walls should be sloped to within 1.2 metres (4 feet) of the trench bottom (Figure 8).

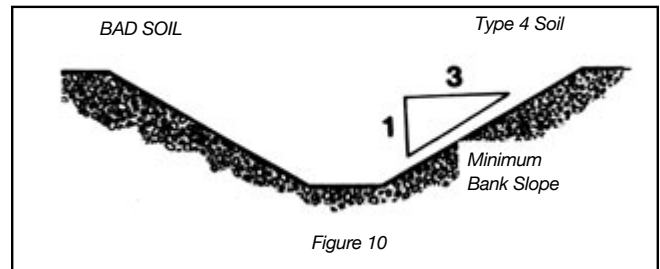
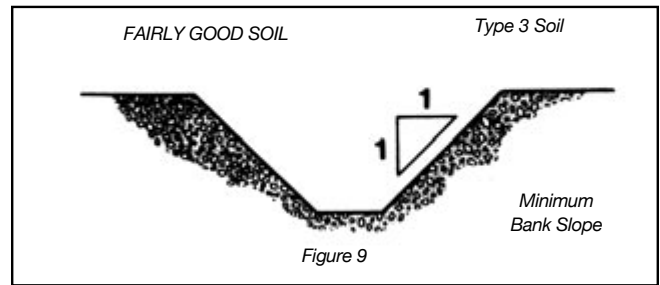
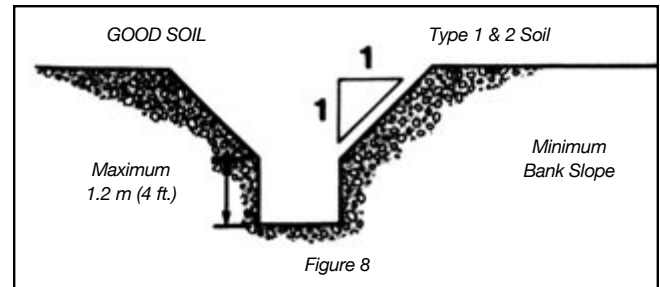

For Type 3 soil, cut walls back at a gradient of 1 to 1 from the trench bottom (Figure 9).

For Type 4 soil, slope the walls at 1 to 3. That's 3 metres back for every 1 metre up from the trench bottom (Figure 10).

Although sloping can reduce the risk of a cave-in, the angle must be sufficient to prevent spoil not only from sliding back but also from exerting too much pressure on the trench wall (Figure 11).

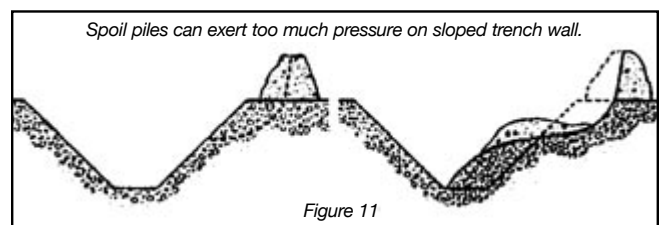

Sloping is commonly used with shoring or trench boxes to cut back any soil above the protected zone. It is also good practice to cut a bench at the top of the shoring or trench (Figure 12).

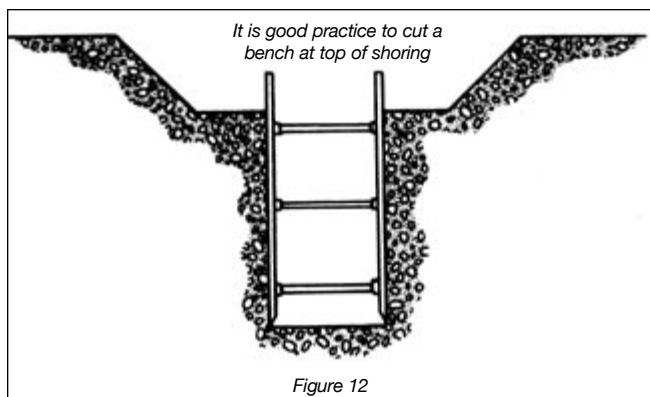

If sloping is to be used above a trench box, the top portion of the cut should first be sloped 1 to 1 (or 1 to 3 for Type 4 soil — see previous page). Then the box should be lowered into the trench (Figure 13).

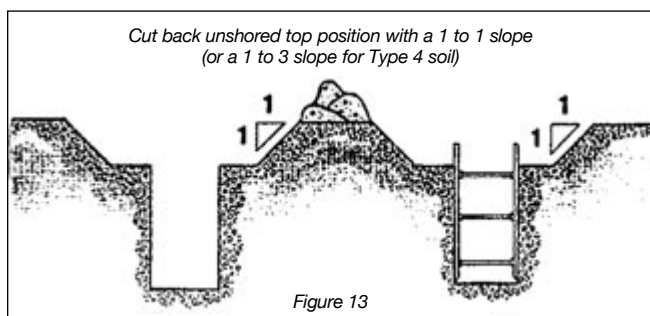

Trench boxes

Trench boxes are not usually intended to shore up or otherwise support trench walls. They are meant to protect workers in case of a cave-in.

Design drawings and specifications for trench boxes must be signed and sealed by the professional engineer who designed the system and must be kept on site by the constructor.

Boxes are normally placed in an excavated but unshored trench and used to protect personnel. A properly designed trench box is capable of withstanding the maximum lateral load expected at a given depth in a particular soil condition.

Trenches near utilities, streets, and buildings may require a shoring system.

As long as workers are in the trench they should remain inside the box. Workers must not be inside the trench or the box when the box is being moved. A ladder must be set up in the trench box at all times.

Excavation should be done so that the space between the trench box and the excavation is minimized (Figure 14).

The two reasons for this are

- 1) allowing closer access to the top of the box
- 2) limiting soil movement in case of a cave-in.

Check the drawings and specifications for the trench box to see if the space between the box and the trench wall needs to be backfilled and the soil compacted.

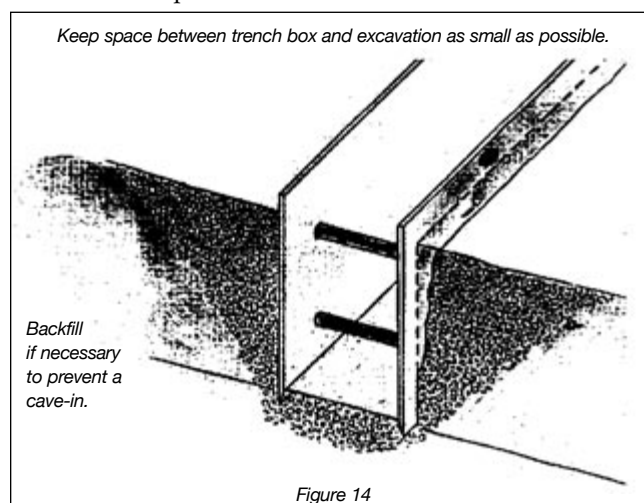

Shoring

Shoring is a system which “shores” up or supports trench walls to prevent movement of soil, underground utilities, roadways, and foundations.

Shoring should not be confused with trench boxes. A trench box provides worker safety but gives little or no support to trench walls or existing structures such as foundations and manholes.

The two types of shoring most commonly used are timber and hydraulic. Both consist of posts, wales, struts, and sheathing.

Figures 15 and 16 identify components, dimensions, and other requirements for timber shoring in some typical trenches.

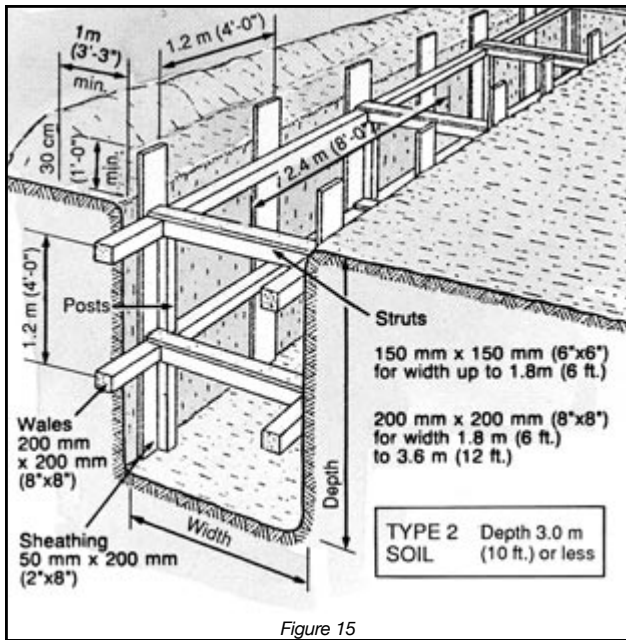

Figure 15

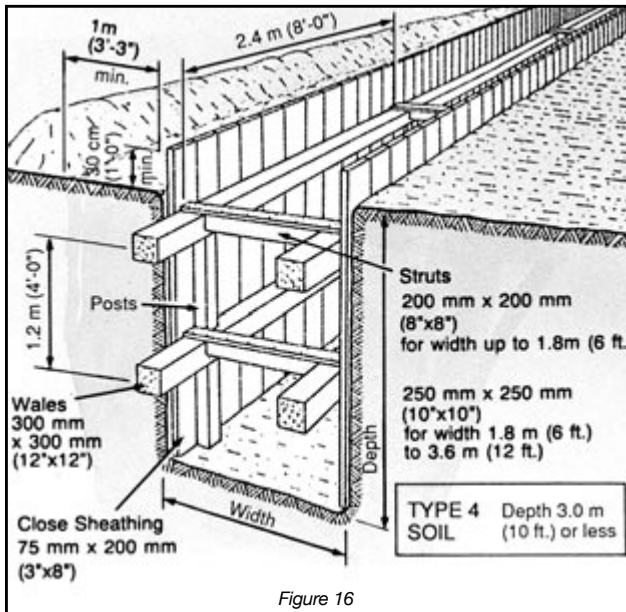

Figure 16

“Hydraulic shoring” refers to prefabricated strut and/or wale systems in aluminum or steel. Strictly speaking, these may not operate hydraulically. Some are air-operated or manually jacked. Design drawings and specifications for prefabricated shoring systems must be kept on site.

One major advantage of hydraulic shoring over some applications of timber shoring is safety during installation. Workers do not have to enter the trench to install the system. Installation can be done from the top of the trench.

Most hydraulic systems are

- light enough to be installed by one worker
- gauge-regulated to ensure even distribution of pressure along the trench line
- able to “pre-load” trench walls, thereby using the soil’s natural cohesion to prevent movement.
- easily adapted to suit various trench depths and widths.

Wherever possible, shoring should be installed as excavation proceeds. If there is a delay between digging and shoring, no one must be allowed to enter the unprotected trench.

All shoring should be installed from the top down and removed from the bottom up.

Access/egress

Whether protected by sloping, boxes, or shoring, trenches must be provided with ladders so that workers can enter and exit safely (Figure 17).

Ladders must

- be placed within the area protected by the shoring or trench box
- be securely tied off at the top
- extend above the shoring or box by at least 1 metre (3 feet)

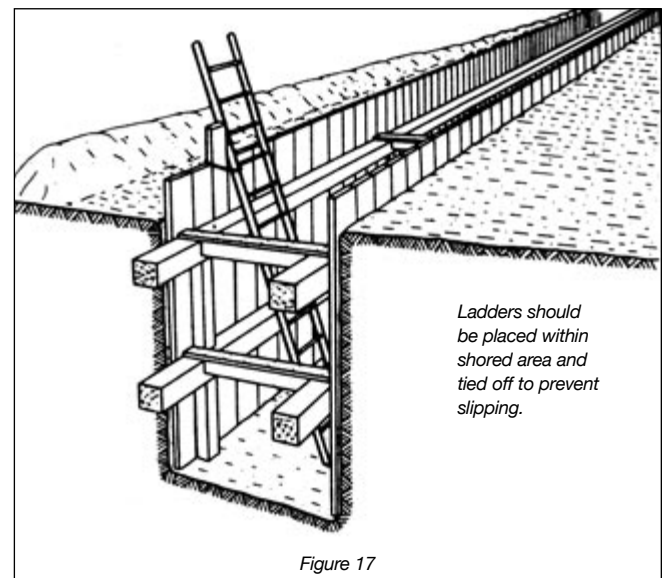

Figure 17

- be inspected regularly for damage.

Ladders should be placed as close as possible to the area where personnel are working and never more than 7.5 metres (25 feet) away.

Anyone climbing up or down must always face the ladder and maintain 3-point contact. This means that two hands and one foot or two feet and one hand must be on the ladder at all times.

Maintaining 3-point contact also means hands must be free for climbing. Tools and materials should not be carried up or down ladders. Pumps, small compactors, and other equipment should be lifted and lowered by methods that prevent injury from overexertion and falling objects.

Inspection

Inspection is everyone's responsibility. Whatever the protective system, it should be inspected regularly.

Check hydraulic shoring for leaks in hoses and cylinders, bent bases, broken or cracked nipples, and other damaged or defective parts (Figure 18).

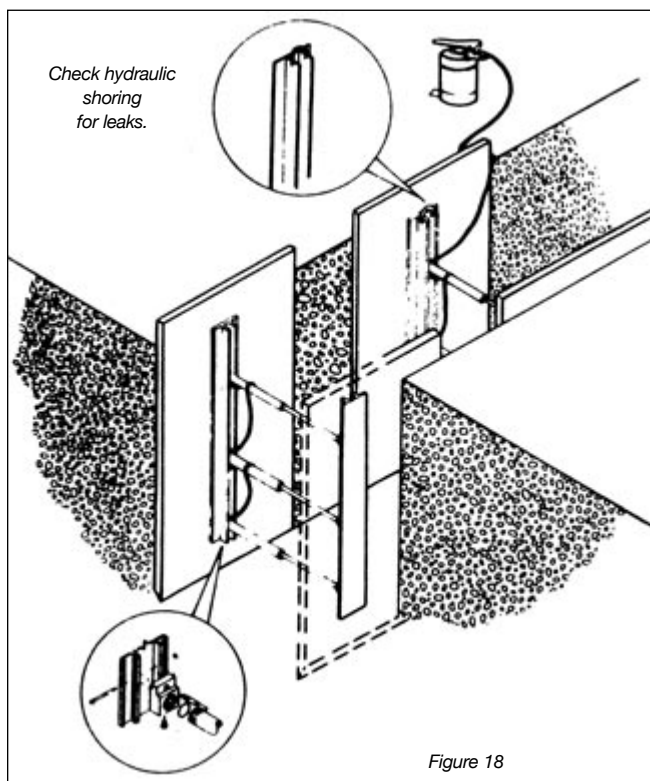

Figure 18

Check timber shoring before installation. Discard damaged or defective lumber. After installation, inspect wales for signs of crushing. Crushing indicates structural inadequacy and calls for more struts (Figure 19).

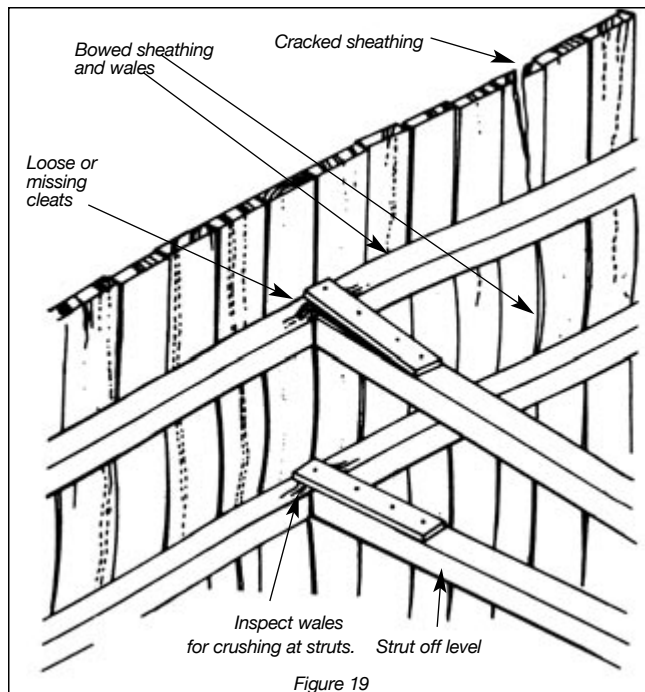

Figure 19

Inspect trench boxes for structural damage, cracks in welds, and other defects (Figure 20). During use, check the box regularly and often to make sure that it is not shifting or settling much more on one side than the other. If it is, leave the trench and ask the supervisor to check for stability.

Check ground surface for tension cracks which may develop parallel to the trench at a distance one-half to three-quarters of the trench depth (Figure 21). If cracks are detected, alert the crew and check all protective systems carefully.

Check areas adjacent to shoring where water may have entered the trench. A combination of water flow and granular soils can lead to undermining of the trench wall. Such conditions have caused fatalities.

Finally, make sure that tools, equipment, material, and spoil are kept at least 1 metre (3 feet) back from the edge of the trench to prevent falling objects from striking workers.

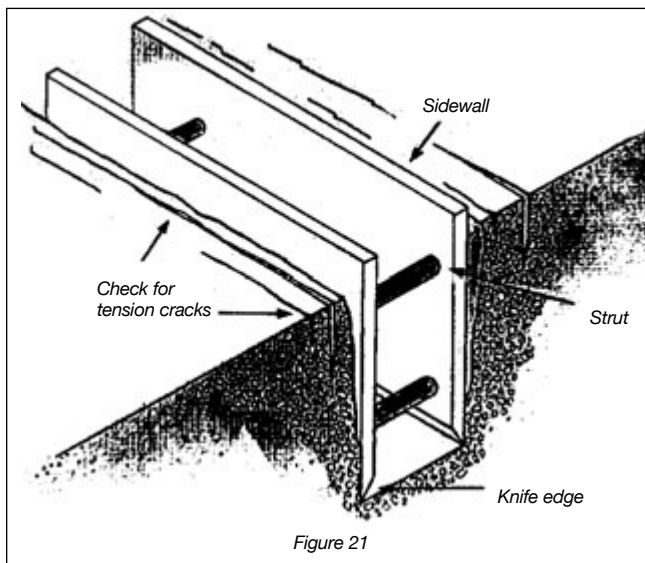
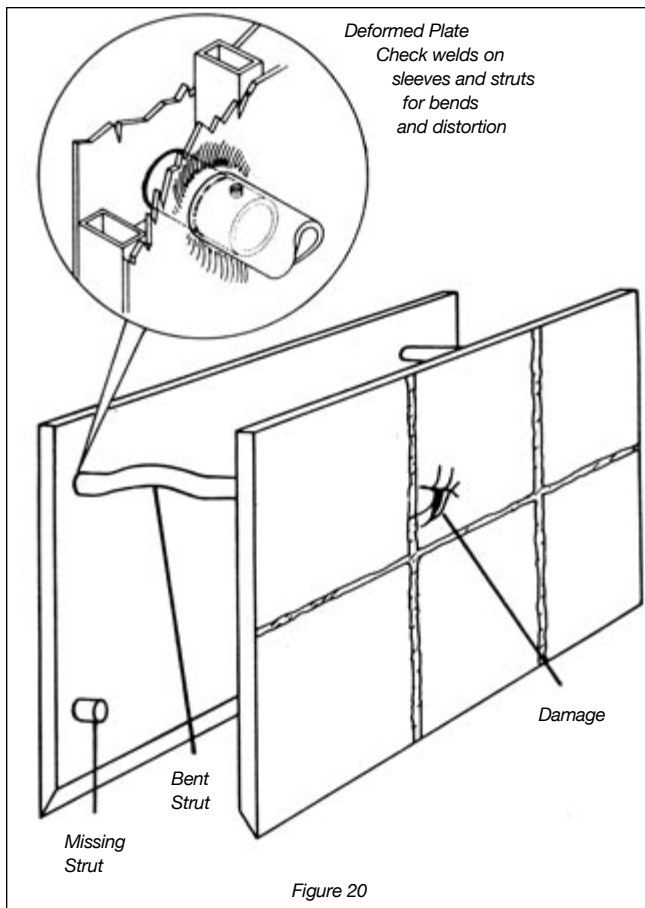

Summary

Sloping, trench boxes, and shoring are meant to protect workers from the hazards of cave-ins.

The method chosen must meet the specific requirements of the job at hand. Depending on application, one method may be better suited to certain conditions than another.

Whatever the system, inspect it regularly to make sure that it remains sound and reliable.

Remember: Never enter a trench more than 1.2 metres (4 feet) deep unless it is sloped, shored, or protected by a trench box.

Other Hazards and Safeguards

The risk of a cave-in is not the only hazard in trenching. Injuries and deaths are also related to six other major areas:

- personal protective equipment
- utilities underground and overhead
- materials handling and housekeeping
- heavy equipment
- traffic control
- confined spaces.

Personal protective equipment

Personal protective equipment is an important defence against certain types of injury.

Injuries from falling and flying objects, for instance, can be reduced by wearing hard hats and eye protection.

Everyone on a construction project must wear Grade 1 safety boots certified by the Canadian Standards Association (CSA) as indicated by the CSA logo on a green triangular patch (Figure 22).

Under the wet, muddy conditions often encountered in trenching, you may also require rubber safety boots displaying the same CSA logo on a green triangular patch.

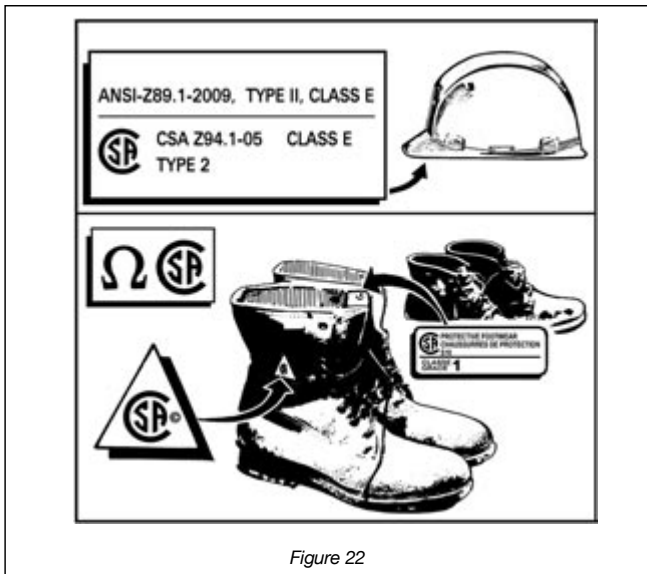

Figure 22

It is mandatory for everyone on a construction project to wear head protection in the form of a hard hat that complies with the current Construction Regulation.

Eye protection is strongly recommended to prevent injuries from construction operations such as chipping and drilling and site conditions such as dust.

Personnel exposed for long periods to noisy equipment should wear hearing protection.

Work in confined spaces such as manholes and valve chambers may require respiratory protection against hazardous atmospheres. See “Confined Spaces” in this manual for more information.

See IHSA’s *Construction Health and Safety Manual* (M029) for more information on personal protective equipment.

Underground utilities

Locates — Services such as gas, electrical, telephone, and water lines must be located by the utility before excavation begins.

Request locates for all the underground utilities in the area where excavation will be taking place. The contractor responsible for the work must contact the owners of any underground utilities that may be in that location or phone

Ontario One Call (1-800-400-2255). Some utilities are not part of the Ontario One Call system. Contact those utilities separately for locate requests.

The service locate provided by the utility owner should indicate, using labelled stakes, flags, and/or paint marks, the centre line of the underground utility in the vicinity of the proposed excavation.

The excavator should not work outside of the area covered by the locate stakeout information without obtaining an additional stakeout.

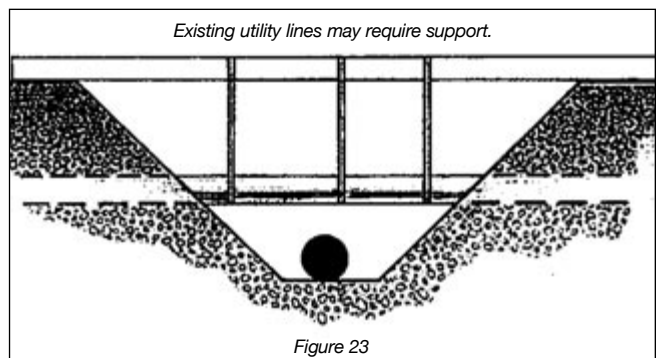

Figure 23

Locate stakeout accuracy should be considered to be 1 metre on either side of the surface centre line locate unless the locate instructions specifically indicate other boundary limits.

Where the underground utility cannot be located within the locate stakeout limits, the utility owner should be contacted to assist with the locate.

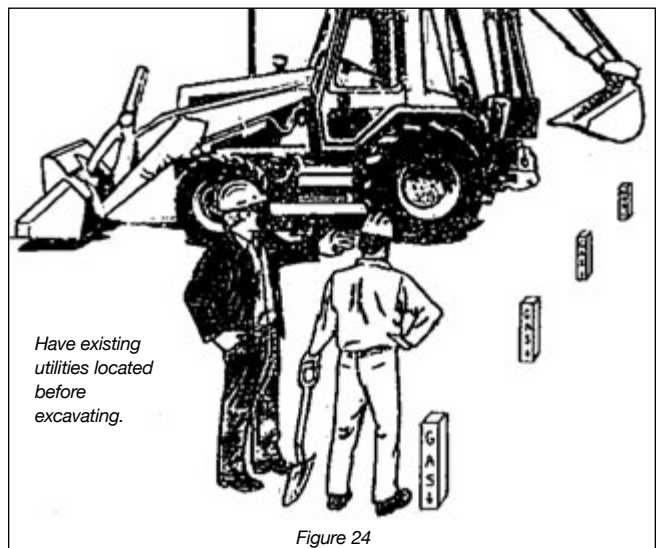

Figure 24

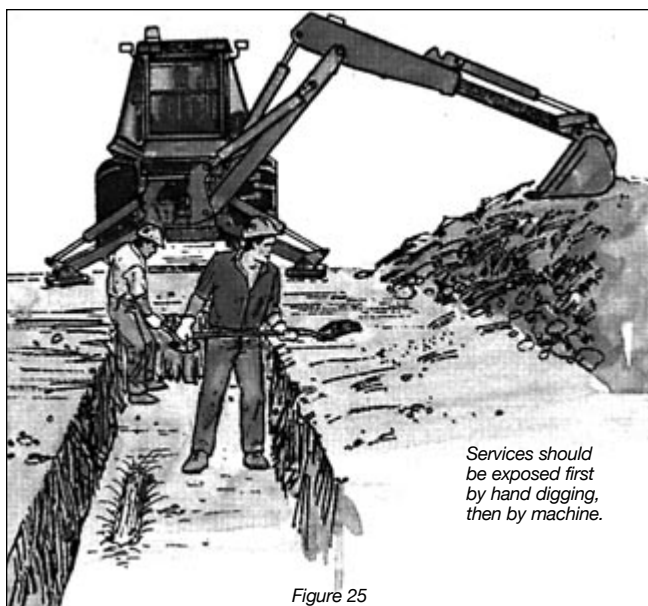

Figure 25

Mechanical excavation equipment should not be used within the boundary limits of the locate without first digging a hole or holes using the procedure below to determine the underground utility's exact centre line and elevation.

Test holes should, in general, be excavated by one of the following methods:

- (a) machine excavation immediately outside the boundary limits and then hand digging laterally until the underground utility is found; or
- (b)
 - (i) hand excavation perpendicular to the centre line of the locate in cuts of at least 1 foot in depth;
 - (ii) mechanical equipment can then be used carefully to widen the hand-dug trench to within one foot of the depth of the hand-dug excavation;
 - (iii) repeat steps (i) and (ii) until the utility is located; or
- (c) a hydro-excavation system — acceptable to the owner of the utility — which uses high-pressure water to break up the cover material and a vacuum system to remove it can be used to locate the underground utility. See the next section for more information about hydro excavation.

Centre line locates should be provided and test holes dug where a representative of the utility identifies

- (a) alignment changes
- (b) changes in elevation.

Where an underground utility may need support or where it may shift because of disturbance of surrounding soil due to excavation, guidelines for excavation and support should be obtained from the owner of the utility (Figure 23).

Hydro excavation —

Precautions:

- Before starting work, use barricades and signs to inform unauthorized personnel to keep out.
- Employers must ensure that workers are properly trained on the machine they are using.
- When exposing underground power utilities the operators should use bonding mats.
- Use a fall-protection system when required.
- Keep clear of the vacuum. It is powerful and can cause serious injury or even death if you are caught in the tube.
- Some utility owners set limits for the water pressure that can be used near their buried plan. Check with the utility owner before excavating.
- Excavators can refer to the following for further information:
 - TSSA/ESA *Guidelines for Excavations in the Vicinity of Gas Lines*
 - Safe Practice Guide *Excavating with Hydrovacs in the Vicinity of Underground Electrical Plant*, available from IHSA (www.ihsa.ca).

Workers using or in the vicinity of hydro excavation:

- Keep away from the operation if you are not directly involved in the work.
- Wear hearing protection if working in vicinity of the hydrovac truck.
- Be aware of the hazards, such as slips from the runoff water and ice during the winter.
- Wear appropriate eye and face protection such as safety glasses and faceshields. They will protect you from getting any airborne debris (caused by splashing) in your eyes.
- Keep clear of the vacuum. It is powerful and can cause serious injury or even death if you are caught in the tube.

Breaks — Breaks in electrical, gas, and water services can cause serious injuries, even deaths. Hitting an underground electrical line can result in electrocution, while hitting a gas line can cause an explosion. A broken water line can release a sudden rush of water, washing out support systems and causing a cave-in.

Cutting telephone lines can create a serious problem if emergency calls for police, fire, or ambulance are required.

In the event of gas line contact, call the gas company immediately. The company will check the line and close down the supply if necessary.

If a leak is suspected, people in the immediate area should be told to evacuate. Where service to a building or home has been struck, people inside should be advised to leave doors and windows open; shut off appliances, furnaces, and other sources of ignition; and vacate the premises until the gas company declares it safe to return.

Construction personnel should take two precautions.

- 1) Put out smoking materials and shut off other sources of ignition such as engines and equipment.

- 2) Leave the trench immediately. Gas can collect there.

Overhead powerlines

When equipment operates within reach of (and could therefore encroach on) the minimum permitted distance from a live overhead powerline, the constructor must have written procedures in place to prevent the equipment from encroaching on the minimum distance.

Voltage Rating of Powerline	Minimum Distance
750 or more volts, but not more than 150,000 volts	3 metres (10')
more than 150,000 but not more than 250,000 volts	4.5 metres (15')
more than 250,000 volts	6 metres (20')

If equipment touches a high-voltage line, the operator should take the following precautions.

- 1) Stay on the machine. Don't touch equipment and ground at same time. Touching anything in contact with the ground could be fatal.
- 2) Anyone operating accessory equipment should also remain on that equipment. They should also avoid making contact with the ground and the equipment at the same time.

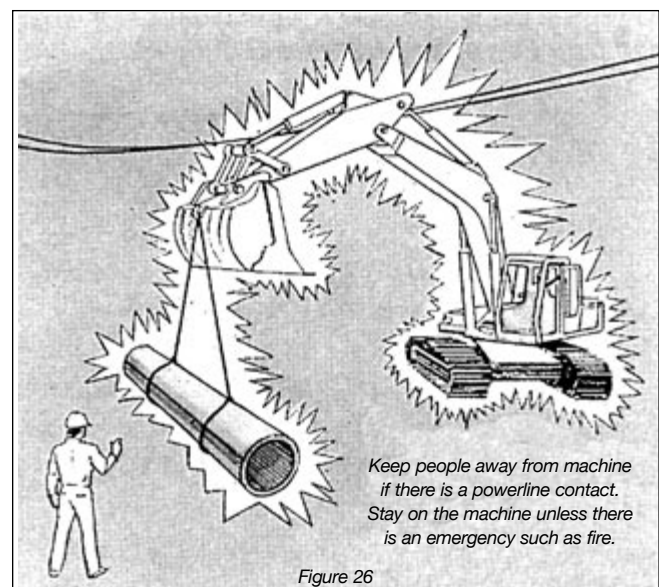
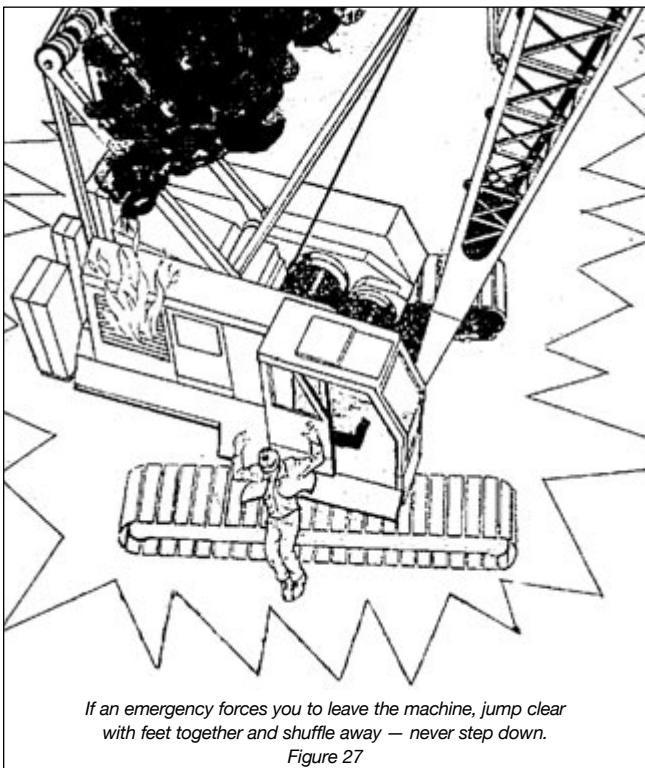

Figure 26

- 3) Keep others away. Warn them not to touch the load, load lines, boom, bucket, or any other part of the equipment (Figure 26).
- 4) Get someone to call the local utility to shut off power.
- 5) If possible, the operator (while remaining on the machine) can try to break contact by moving the machine clear of the wires.

Warning: Beware of time relays. Even after breakers are tripped by line damage, relays may be triggered to restore power.

- 6) If the operator can't break contact by moving the machine (while remaining on it), do not move the machine until the utility shuts down the line and confirms that power is off.
- 7) If an emergency such as fire forces you to leave the machine, jump clear (Figure 27). Never step down. If part of your body contacts the ground while another part touches the machine, current will travel through you.



- 8) Jump with feet together and shuffle away in small steps. Don't take big steps. With voltage differential across the ground, one foot may be in a higher voltage area than the other. The difference can kill you (Figure 28).

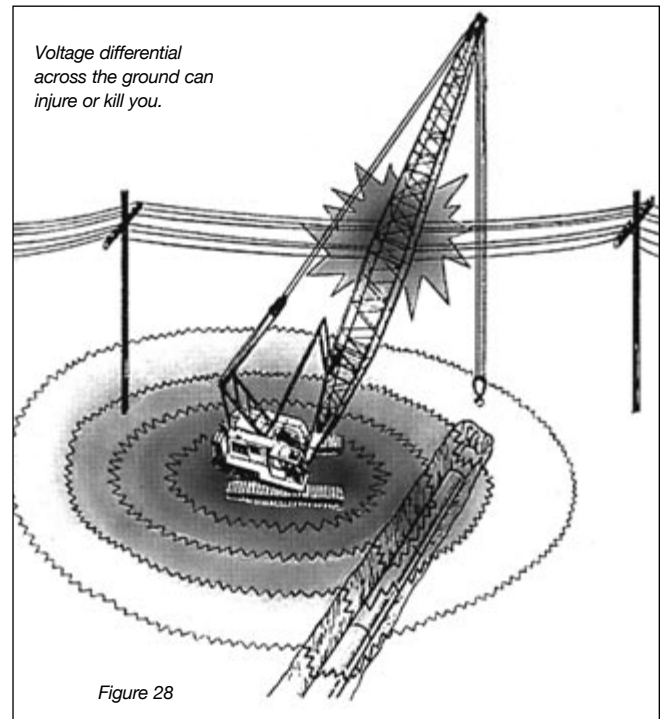

Special precautions are required for casualties in contact with live powerlines or equipment.

- 1) Never touch the casualty or anything in contact with the casualty.
- 2) If possible, break contact. Use a dry board, rubber hose, or dry polypropylene rope to move either the casualty or the line. An object can sometimes be thrown to separate the casualty from the wire.

Warning : Touching the casualty, even with dry wood or rubber, can be dangerous. With high voltage lines, objects that are normally insulators can become conductors.

- 3) Call emergency services — in most cases ambulance, fire department, and utility.

- 4) Provide first aid once the casualty is free of contact. If the casualty is not breathing, begin artificial respiration immediately (mouth-to-mouth is most efficient) or CPR. Apply cold water to burns and cover with clean dressing.

Materials handling

Many lost-time injuries in trenching involve materials handling. Moving rock and soil, lifting pipe and manhole sections, laying down bedding material, or lowering pumps and compactors into the trench can all be hazardous.

Pipe — Trucks should always be on level ground when pipe is unloaded. Pipe should be chocked or staked before tie-downs are released. These measures will reduce the risk of sections rolling off the truck.

Plastic and small diameter pipe is often banded with metal straps. Be careful cutting the straps. They are under tension and can fly back and hit you.

Personnel often injure fingers and hands when laying and joining sections of pipe. While sections

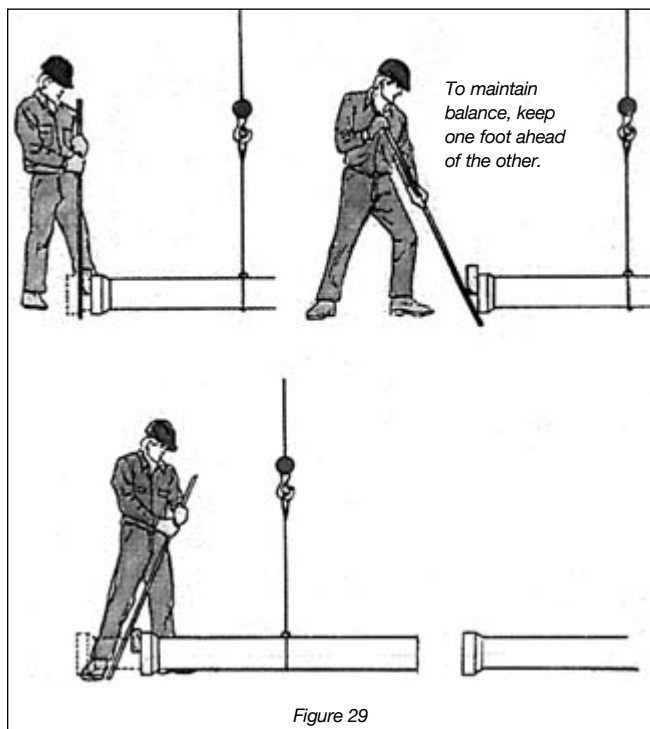

Figure 29

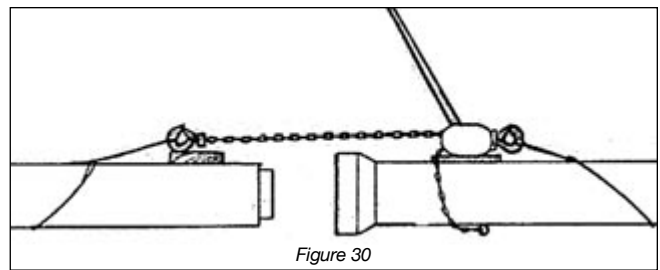

Figure 30

are suspended from hoisting equipment, keep hands away from slings or chokers in tension. When guiding and pushing sections together by hand, never curl fingers around ends or flanges.

As pipe is placed along the trench, each section should be blocked or set so that it cannot roll and cause injury.

Back injuries can occur when small-diameter pipe is being homed into position (Figure 29). The worker pushing the bar should place his feet directly in front of the pipe with one foot ahead of the other.

Large-diameter pipe should be placed with pipe pullers (Figure 30).

Bedding material — Personnel shovelling bedding material in the trench are usually working in a confined area where footing is muddy and uneven.

The result can be overexertion or slips and falls leading to back and other injuries. Mechanical equipment can significantly reduce this hazard. For instance, bedding material can be put in the excavator bucket with a front-end loader, then spread evenly along the trench bottom.

Rigging — Rigging is essential to safe, efficient materials handling since pipe, manhole sections, and equipment are lowered into the trench by cranes or other hoisting devices.

Rigging these loads properly can prevent injury.

Inspect slings and rigging hardware regularly and replace any damaged or worn devices.

With **nylon web slings**, damage is usually easy to spot: cuts, holes, tears, worn or distorted fittings, frayed material, broken stitching, heat

burns. Damaged web slings should be replaced.

When using **wire rope slings**, inspect for broken wires, worn or cracked fittings, loose seizings and splices, flattening, and corrosion. Knots or kinks indicate that wire rope slings are permanently damaged and should not be used.

Damage most often occurs around thimbles and fittings. Don't leave wire rope lying on the ground for any length of time in damp or wet conditions.

Eyes in wire rope slings should be fitted with thimbles. To make an eye with clips, put the U-bolt section on the dead or short end of the rope and the saddle on the live or long end (Figure 31). Remember — never saddle a dead horse.

At least three clips are required for wire rope up to 5/8" diameter, and four are required for wire rope greater than 5/8" up to and including 7/8" diameter.

Avoid binding the eye section of wire rope slings around corners. The bend will weaken the splice or swaging.

When using choker hitches, do not force the eye down towards the load once tension is applied.

When using **chain slings**, inspect for elongated links. A badly stretched link tends to close up (Figure 32).

Look for bent, twisted, or damaged links that can result when chain has been used to lift a

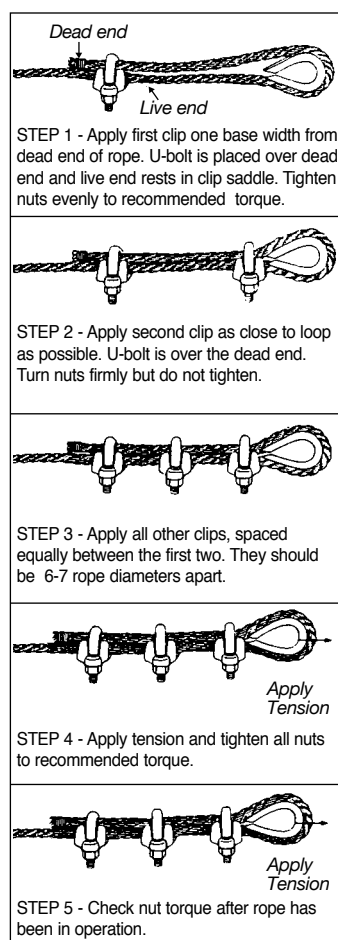

Figure 31

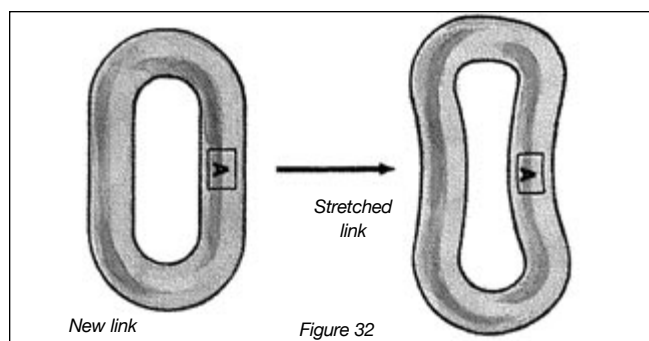

Figure 32

load with unprotected sharp edges.

Inspect for cracks. Although sometimes hard to detect, cracks always indicate that the chain should be removed from service. Also look for gouges, chips, cuts, dents, peen marks, and corrosive wear at points where links bear on each other.

Rigging Tips

- Wherever possible, lower loads on adequate blockage to prevent damage to slings.
- Keep hands away from pinch points when slack is being taken up.
- Stand clear while the load is being lifted and lowered or when slings are being pulled out from under it.
- Use tag lines to control swinging, swaying, or other unwanted movement of the load.

Housekeeping

Accident prevention depends on proper housekeeping at ground level and in the trench.

At the top of the trench, sections of pipe, unused tools and timber, piles of spoil, and other material must be kept at least 1 metre (3 feet) away from the edge.

The slips and falls common on excavation projects can be reduced by cleaning up scrap and debris. Trenches should also be kept as dry as possible. Pumps may be required.

Proper housekeeping is especially important

Ladders should be placed within shored area and tied off to prevent slipping.

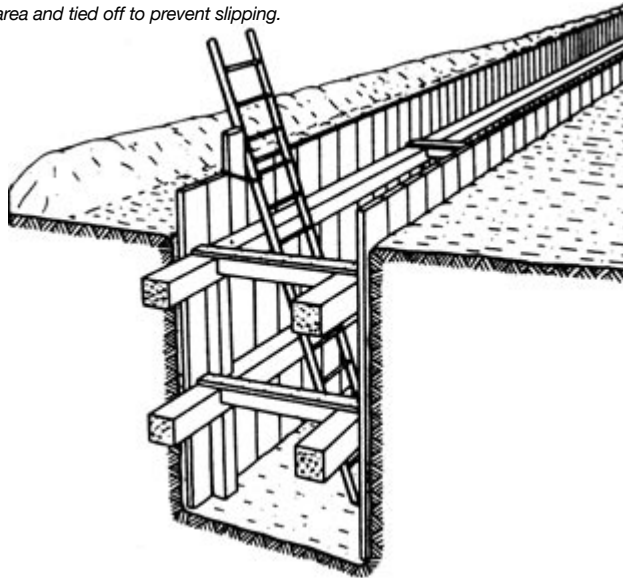

Figure 33

around ladders. The base and foot of the ladder should be free of garbage and puddles. Ladders should be tied off at the top, placed in protected areas, and inspected regularly for damage (Figure 33).

 Load Up	 Load Down	 Swing Left	 Swing Right
 Turn Left	 Turn Right	 Travel	 This Far To Go
 Everything Slow	 Stop Engine	 Stop	 Emergency Stop
 Boom Up	 Boom Down	 Telescope In	 Telescope Out
 Dipper In	 Dipper Out	 Counter Rotate	 Counter Rotate
 Open Bucket	 Close Bucket	 Dog Everything	NO RESPONSE SHOULD BE MADE TO UNCLEAR SIGNALS

Heavy equipment

Excavators, backhoes, and other heavy equipment can cause injuries and fatalities to operators and personnel on foot.

Excavator handsignals — Communicate clearly with your co-workers. Use the following handsignals.

Operators — Improperly climbing on and off equipment has caused injuries to operators for many years. The best prevention is to maintain 3-point contact (Figure 34).

Use 3-point contact on steps and rails.

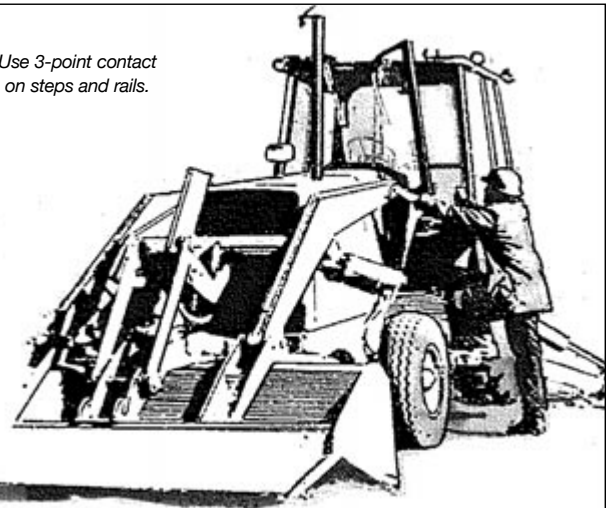

Figure 34

Equipment should be fitted with steps, grabs, and rails that are repaired or replaced when damaged.

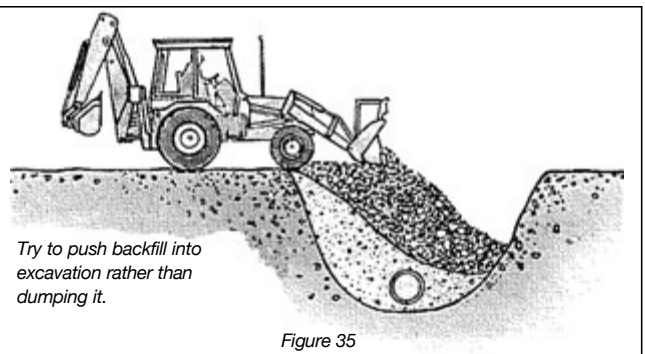

Figure 35

Operators have also suffered serious injuries when equipment upsets because of soil failure near excavations (Figure 35), improper loading on floats, or inadvertently backing into excavations.

Moving equipment — Signallers are required by law

- if the operator's view of the intended path of travel is obstructed, or
- if a person could be endangered by the moving equipment or its load.

Back-up alarms are required on dump trucks and recommended for all moving equipment. Where vehicles have to operate in reverse, warning signs must be conspicuously posted.

Ground rules for truck drivers

- Understand and obey the signaller at all times.
- Remain in the cab where possible.
- Ensure that mirrors are clean, functional, and properly adjusted.
- Do a circle check after being away from the truck for any length of time (walk around the truck to ensure the area is clear before moving).
- Stop immediately when a signaller, worker, or anyone else disappears from view.

Workers on foot — Personnel on foot are frequently stuck by machine attachments such as excavator buckets and bulldozer blades when they stand or work too close to operating equipment, especially during unloading and excavation.

Workers on foot are also injured and killed by equipment backing up.

Ground rules for workers on foot

- Beware of common operator blind spots. See chapter on Backing Up in this manual.
- Stay alert to the location of equipment around you.
- Avoid entering or standing in blind spots.
- **Always remain visible to the operator.**

Make eye contact to ensure that you are seen.

- Never stand behind a backing vehicle.
- Remember — the operator may be able to see you while you are standing but not when you kneel down or bend over.

Signallers — In heavily travelled or congested work areas, a signaller may be necessary to direct equipment and prevent injuries and deaths caused by vehicles backing up.

Ground rules for signallers

- Wear a fluorescent or bright orange safety vest.
- Use standard hand signals (Figure 37).
- Stand where you can see and be seen.
- Stay in full view of the operator and the intended path of travel.
- Know where the operator's blind spots are.
- Warn other workers to stay clear of equipment.

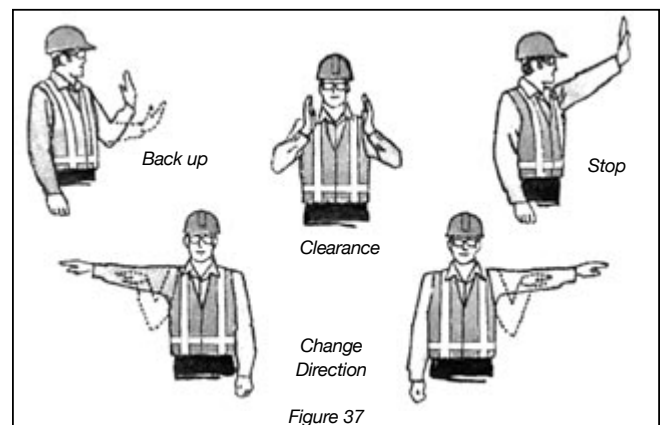

Traffic control

On trenching projects along public roadways, the construction crew must be protected from traffic. Regulations specify the following methods for protecting personnel:

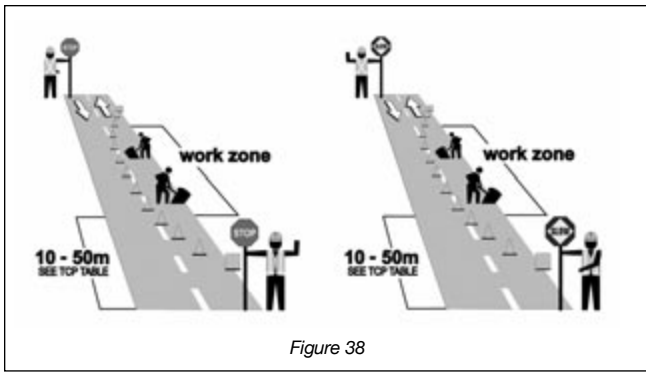

Figure 38

- traffic control persons (TCPs) using signs (Figure 38)
- warning signs
- barriers
- lane control devices
- flashing lights or flares.

Supervisors must train TCPs on site and explain the nature of the project, where construction equipment will be operating, and how public traffic will flow. TCPs must wear a fluorescent or bright orange safety vest.

Training must also include the proper use of the STOP/SLOW sign, where to stand, how to signal, and communication with other TCPs. (See the chapter on Traffic Control in IHSA's *Construction Health and Safety Manual* (M029).)

After presenting this information, the supervisors must give TCPs written instructions in a language they can understand.

Confined spaces

A confined space is defined as a place

- a) that is **partially or fully enclosed**
- b) that is not both designed and constructed for **continuous human occupancy**, and
- c) where **atmospheric hazards** may occur because of its construction, location, or contents, or because of work that is done in it.

All three criteria have to be met before a space

is defined as a confined space.

In the sewer and watermain industry, confined spaces can be locations such as excavations, manholes, valve chambers, pump stations, and catch basins. The atmosphere in these spaces may be

- toxic
- oxygen-deficient
- oxygen-enriched
- explosive.

Sewage not only smells bad but can create dangerous atmospheres. Decaying waste releases hazardous gases such as hydrogen sulfide and methane. The bacteria in sewage are not only a source of infection but can also consume oxygen and leave the atmosphere oxygen-deficient.

Other sources of contamination can include

- fumes from welding or patching compounds
- chemicals from waste disposal sites
- engine exhaust
- propane or other explosive gases that are heavier than air and collect in the bottom of the trench
- leaks from underground storage tanks
- decomposing material in landfill sites.

Protecting the health and safety of personnel starts with some basic steps.

- A competent worker must test a confined space to determine whether it is hazard-free before a worker enters, and continue testing to ensure that it remains hazard-free.
- Where tests indicate safe air quality, workers may be allowed to enter the confined space.

- Where tests indicate a hazardous level of fumes, vapours, gases, or oxygen, entry must not be allowed until the space has been adequately ventilated and subsequent tests indicate that the air is safe to breathe.
- Where possible, mechanical venting should be continued in any confined space containing hazardous levels of fumes, vapours, gases, or oxygen, even after venting has corrected the hazard. The space must also be continuously monitored while personnel are working there.
- In situations where ventilation has removed a hazard, workers entering the space should still wear rescue harnesses attached to individual lifelines. A worker should also be posted at the entrance prepared, equipped, and trained to provide rescue in an emergency. For rescue situations, workers entering the space should wear supplied-air respirators (Figure 40).

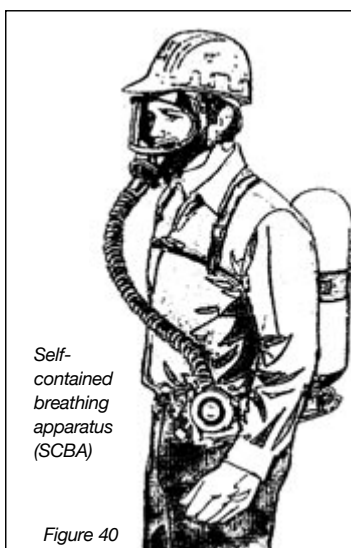

For more information on confined spaces and controls, see the chapter on Confined Spaces in IHSA's *Construction Health and Safety Manual* (M029).

Hydrostatic testing

Hydrostatic testing involves entry into a confined space such as a manhole or valve chamber. The procedures listed above should be followed.

Testing new lines can be very hazardous if components break or plugs let go. For that

reason, additional precautions are required.

When testing watermains, ensure that all lines, elbows, and valves are supported and equipped with thrust blocks. Otherwise the line could come apart under test pressure.

Arrange watermain testing so that lines are pressurized when no one is in the manhole or valve chamber.

For sewer line testing, all requirements for entering confined spaces apply.

Ensure that plugs are secure. No one should be in a manhole when the upstream line is being filled. Plugs that are not properly installed can let go, causing injury and letting a manhole fill quickly, depending on the size of the line.

Flooding is another reason why no one should be in a manhole without a rescue harness and a worker outside ready and prepared for an emergency.

Emergency Procedures

General

Emergency telephone numbers — ambulance, fire, police, local utilities, senior management, Ministry of Labour — should be posted in the field office for quick reference.

If someone is seriously injured, take the following steps.

- 1) Protect the area from hazards.
- 2) Prevent further injury to the casualty.
- 3) Administer first aid.
- 4) Call an ambulance or rescue unit.
- 5) Have someone direct the ambulance or rescue unit to the accident scene.

All projects must have a person qualified and certified to provide first aid.

Cave-ins

It is natural to try to rescue casualties caught or

buried by a cave-in. But care must be taken to prevent injury and death to rescuers, whether from a further cave-in or other hazards.

The following procedures may be suitable, depending on conditions.

- 1) To get down to the casualty, use a tarpaulin, fencing, plywood, or similar material that can cover the ground and will ride up over any further cave-in.
- 2) Sometimes a further cave-in can be prevented by placing a backhoe bucket against the suspected area or excavating it.
- 3) Rescue workers should enter the trench with ropes and wear rescue harnesses if possible.
- 4) To prevent further injury, remove the casualty by stretcher whenever possible. Tarps or ladders can be used as a makeshift stretcher.
- 5) Stabilize the casualty.

Breathing — Ensure that the casualty is breathing. If not, open the airway and start artificial respiration immediately. Mouth-to-mouth is the most efficient method.

Bleeding — Control external bleeding by applying direct pressure, placing the casualty in a comfortable position, and elevating the injured part if possible.

Unconsciousness — This is a priority because it may lead to breathing problems. An unconscious person may suffocate when left lying face up. If injuries permit, unconscious persons who must be left unattended should be

placed in the recovery position (Figure 41).

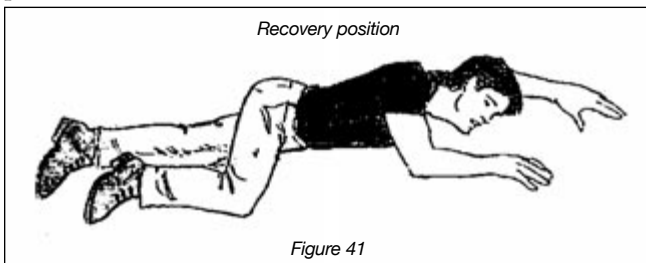

APPENDIX A

THE “EXCAVATIONS” PART OF THE CONSTRUCTION REGULATION (ONTARIO REGULATION 213/91)

REVIEW QUIZ

The “Excavations” part of the Construction Regulation (Ontario Regulation 213/91)

Part III Excavations

Interpretation

222. In this Part,

“engineered support system” means an excavation or trench shoring system, designed for a specific project or location, assembled in place and which cannot be moved as a unit;

“hydraulic support system” means a system capable of being moved as a unit, designed to resist the earth pressure from the walls of an excavation by applying a hydraulic counter pressure through the struts;

“prefabricated support system” means a trench box, trench shield or similar structure, composed of members connected to each other and capable of being moved as a unit, and designed to resist the pressure from the walls of an excavation but does not include a hydraulic support system;

“pressure”, in relation to a wall of an excavation, means the lateral pressure of the earth on the wall calculated in accordance with generally accepted engineering principles and includes hydrostatic pressure and pressure due to surcharge. O. Reg. 213/91, s. 222.

223. This Part applies to all excavating and trenching operations. O. Reg. 213/91, s. 223.

Entry and Working Alone

224. No person shall enter or be permitted to enter an excavation that does not comply with this Part. O. Reg. 213/91, s. 224.

225. Work shall not be performed in a trench unless another worker is working above ground in close proximity to the trench or to the means of access to it. O. Reg. 213/91, s. 225.

Soil Types

226. (1) For the purposes of this Part, soil shall be classified as Type 1, 2, 3 or 4 in accordance with the descriptions set out in this section. O. Reg. 213/91, s. 226 (1).

(2) Type 1 soil,

- (a) is hard, very dense and only able to be penetrated with difficulty by a small sharp object;
 - (b) has a low natural moisture content and a high degree of internal strength;
 - (c) has no signs of water seepage; and
 - (d) can be excavated only by mechanical equipment.
- O. Reg. 213/91, s. 226 (2).

(3) Type 2 soil,

- (a) is very stiff, dense and can be penetrated with moderate difficulty by a small sharp object;
 - (b) has a low to medium natural moisture content and a medium degree of internal strength; and
 - (c) has a damp appearance after it is excavated.
- O. Reg. 213/91, s. 226 (3).

(4) Type 3 soil,

- (a) is stiff to firm and compact to loose in consistency or is previously-excavated soil;
- (b) exhibits signs of surface cracking;
- (c) exhibits signs of water seepage;

- (d) if it is dry, may run easily into a well-defined conical pile; and
 - (e) has a low degree of internal strength. O. Reg. 213/91, s. 226 (4).
- (5) Type 4 soil,
- (a) is soft to very soft and very loose in consistency, very sensitive and upon disturbance is significantly reduced in natural strength;
 - (b) runs easily or flows, unless it is completely supported before excavating procedures;
 - (c) has almost no internal strength;
 - (d) is wet or muddy; and
 - (e) exerts substantial fluid pressure on its supporting system.
O. Reg. 213/91, s. 226 (5).

227. (1) The type of soil in which an excavation is made shall be determined by visual and physical examination of the soil,

- (a) at the walls of the excavation; and
- (b) within a horizontal distance from each wall equal to the depth of the excavation measured away from the excavation.
O. Reg. 213/91, s. 227 (1).

(2) The soil in which an excavation is made shall be classified as the type described in section 226 that the soil most closely resembles. O. Reg. 213/91, s. 227 (2).

(3) If an excavation contains more than one type of soil, the soil shall be classified as the type with the highest number as described in section 226 among the types present. O. Reg. 213/91, s. 227 (3).

Precautions Concerning Services

- 228.** (1) Before an excavation is begun,
- (a) the employer excavating shall ensure

that all gas, electrical and other services in and near the area to be excavated are located and marked;

- (b) the employer and worker locating and marking the services described in clause (a) shall ensure that they are accurately located and marked; and

- (c) if a service may pose a hazard, the service shall be shut off and disconnected. O. Reg. 443/09, s. 6.

(2) If a service may pose a hazard and it cannot be shut off or disconnected, the owner of the service shall be requested to supervise the uncovering of the service during the excavation. O. Reg. 443/09, s. 6.

(3) Pipes, conduits and cables for gas, electrical and other services in an excavation shall be supported to prevent their failure or breakage. O. Reg. 443/09, s. 6.

Protection of Adjacent Structures

229. (1) If an excavation may affect the stability of an adjacent building or structure, the constructor shall take precautions to prevent damage to the adjacent building or structure. O. Reg. 213/91, s. 229 (1).

(2) A professional engineer shall specify in writing the precautions required under subsection (1). O. Reg. 213/91, s. 229 (2).

(3) Such precautions as the professional engineer specifies shall be taken. O. Reg. 213/91, s. 229 (3).

General Requirements

230. Every excavation that a worker may be required to enter shall be kept reasonably free of water. O. Reg. 213/91, s. 230.

231. An excavation in which a worker may work shall have a clear work space of at least 450 millimetres between the wall of the excavation and any formwork or masonry

or similar wall. O. Reg. 213/91, s. 231.

232. (1) The walls of an excavation shall be stripped of loose rock or other material that may slide, roll or fall upon a worker.

O. Reg. 213/91, s. 232 (1).

(2) The walls of an excavation cut in rock shall be supported by rock anchors or wire mesh if support is necessary to prevent the spalling of loose rock.

O. Reg. 213/91, s. 232 (2).

233. (1) A level area extending at least one metre from the upper edge of each wall of an excavation shall be kept clear of equipment, excavated soil, rock and construction material. O. Reg. 213/91, s. 233 (1).

(2) The stability of a wall of an excavation shall be maintained where it may be affected by stockpiling excavated soil or rock or construction materials. O. Reg. 213/91, s. 233 (2).

(3) No person shall operate a vehicle or other machine and no vehicle or other machine shall be located in such a way as to affect the stability of a wall of an excavation. O. Reg. 213/91, s. 233 (3).

(4) If a person could fall into an excavation that is more than 2.4 metres deep, a barrier at least 1.1 metres high shall be provided at the top of every wall of the excavation that is not sloped as described in clauses 234 (2) (e), (f) and (g). O. Reg. 213/91, s. 233 (4).

Note: See subsections 263 (2) and (3) of the *Criminal Code of Canada, R.S.C. 1985, Chap. C-46, as amended, with respect to the duty imposed upon persons in charge of an excavation.*

Support Systems

234. (1) The walls of an excavation shall be supported by a support system that complies with sections 235, 236, 237, 238,

239 and 241. O. Reg. 213/91, s. 234 (1).

(2) Subsection (1) does not apply with respect to an excavation,

- (a) that is less than 1.2 metres deep;
- (b) that no worker is required to enter;
- (c) that is not a trench and with respect to which no worker is required to be closer to a wall than the height of the wall;
- (d) that is cut in sound and stable rock;
- (e) made in Type 1 or Type 2 soil and whose walls are sloped to within 1.2 metres of its bottom with a slope having a minimum gradient of one horizontal to one vertical;
- (f) made in Type 3 soil and whose walls are sloped from its bottom with a slope having a minimum gradient of one horizontal to one vertical;
- (g) made in Type 4 soil and whose walls are sloped from its bottom with a slope having a minimum gradient of three horizontal to one vertical; or
- (h) that is not a trench and is not made in Type 4 soil and with respect to which a professional engineer has given a written opinion that the walls of the excavation are sufficiently stable that no worker will be endangered if no support system is used. O. Reg. 213/91, s. 234 (2).

(3) The opinion in clause (2) (h) shall include details of,

- (a) the specific project and the location thereon;
- (b) any specific condition for which the opinion applies; and

(c) the frequency of inspections.

O. Reg. 213/91, s. 234 (3).

(4) The constructor shall keep on the project a copy of every opinion given by a professional engineer for the purpose of clause (2) (h) while the project is in progress. O. Reg. 213/91, s. 234 (4).

(5) The professional engineer who gives an opinion described in clause (2) (h), or a competent worker designated by him or her, shall inspect the excavation to which the opinion relates as frequently as the opinion specifies. O. Reg. 213/91, s. 234 (5).

235. (1) Subject to subsection (2), a support system shall consist of,

(a) timbering and shoring that meets the requirements of subsection 238 (2), if no hydrostatic pressure is present in the soil, and if the width and depth of the excavation are equal to or less than the width and depth indicated in the Table to section 238;

(b) a prefabricated support system that complies with sections 236 and 237;

(c) a hydraulic support system that complies with sections 236 and 237;
or

(d) an engineered support system that complies with section 236.

O. Reg. 213/91, s. 235 (1).

(2) Where the excavation is a trench and the depth exceeds six metres or the width exceeds 3.6 metres, the support system shall consist of an engineered support system designed for the specific location and project. O. Reg. 213/91, s. 235 (2);
O. Reg. 631/94, s. 7.

236. (1) Every prefabricated, hydraulic or engineered support system shall be designed by a professional engineer.
O. Reg. 213/91, s. 236 (1).

(2) Every prefabricated, hydraulic or engineered support system shall be constructed, installed, used and maintained in accordance with its design drawings and specifications. O. Reg. 213/91, s. 236 (2).

(3) The design drawings and specifications for a prefabricated, hydraulic or an engineered support system,

(a) shall indicate the size of the system and the type and grade of materials of which it is to be made;

(b) shall indicate the maximum depth and the types of soil for which it is designed;

(c) shall indicate the proper positioning of the system in the excavation, including the maximum allowable clearance between the walls of the support system and the walls of the excavation; and

(d) shall indicate how to install and remove the system.

(e) REVOKED: O. Reg. 85/04, s. 21.
O. Reg. 213/91, s. 236 (3);
O. Reg. 85/04, s. 21.

(4) In addition to the requirements of subsection (3), the design drawings and specifications for a hydraulic support system,

(a) shall indicate the minimum working pressure required for the system;
and

(b) shall require the use of a device to ensure the protection of workers if a loss of hydraulic pressure occurs in the system.

O. Reg. 213/91, s. 236 (4).

(5) Before a variation from the design drawings and specifications for a prefabricated, hydraulic or an engineered

support system is permitted, the variation shall be approved in writing by a professional engineer. O. Reg. 213/91, s. 236 (5).

(6) If the soil conditions on a project differ from those assumed by the professional engineer in designing a prefabricated, hydraulic or an engineered support system, a professional engineer shall modify the design drawings and specifications for the actual soil conditions or shall approve the support system for use in the actual soil conditions. O. Reg. 213/91, s. 236 (6).

(7) The constructor shall keep the design drawings and specifications for a prefabricated, hydraulic or an engineered support system at a project while the system is on the project. O. Reg. 213/91, s. 236 (7).

(8) REVOKED: O. Reg. 443/09, s. 7.

237. (1) Subject to subsection (2),

- (a) no prefabricated or hydraulic support system shall be used in type 4 soil;
- (b) the space between the walls of a prefabricated support system and the walls of the excavation shall be restricted to the minimum clearance required for the forward progression of the support system; and
- (c) the walls of a hydraulic support system shall touch the walls of the excavation. O. Reg. 631/94, s. 8.

(2) A prefabricated or hydraulic support system may be used for repairing underground pipe breaks if the system,

- (a) meets the requirements of section 236;
- (b) has four side walls;
- (c) is designed for a maximum depth of 3.6 metres;

- (d) is not used at a greater depth than 3.6 metres;
- (e) is designed to resist all hydrostatic and earth pressures found in type 3 and type 4 soils;
- (f) is installed so as to extend to the bottom of the excavation;
- (g) is installed so that the walls of the system touch the walls of the excavation; and
- (h) is not pulled forward after being installed in the excavation.
O. Reg. 631/94, s. 8.

(3) Before a support system is used as described in subsection (2), the constructor shall submit two copies of its design drawings and specifications to the office of the Ministry of Labour nearest to the project. O. Reg. 631/94, s. 8.

238. (1) In this section,

“cleat” means a member of shoring that directly resists the downward movement of a wale or strut;

“o/c” means the maximum distance measured from the centre of one member of sheathing, wale or strut to the centre of the adjacent member of sheathing, wale or strut;

“post” means a vertical member of shoring that acts as a spacer between the wales;

“10 millimetres gap” means that the space between two adjacent members of sheathing is a maximum of ten millimetres. O. Reg. 213/91, s. 238 (1).

(2) Timbering and shoring referred to in clause 235 (1) (a) for the walls of an excavation with a depth and located in a soil type described in Column 1 of the Table to this section shall meet the corresponding specifications set out in

Columns 2 to 4 of the Table.

O. Reg. 213/91, s. 238 (2).

(3) Every piece of sheathing referred to in the Table to this section shall be made of sound Number 1 Grade spruce and,

- (a) shall be placed against the side of the excavation so that it is vertical;
- (b) shall be secured in place by wales; and
- (c) shall be driven into the soil and firmly secured in place if the excavation is made in Type 3 or 4 soil. O. Reg. 213/91, s. 238 (3).

(4) Every strut referred to in the Table to this section shall be made of sound number 1 structural grade spruce and,

- (a) shall be placed in the excavation so that it is horizontal and at right angles to the wales;
- (b) shall be cut to the proper length and held in place by at least two wedges

driven between the strut and the wales; and

- (c) shall be cleated with cleats that extend over the top of the strut and rest on the wales or that are attached securely to the wales by spikes or bolts. O. Reg. 213/91, s. 238 (4).

(5) Every wale referred to in the Table to this section shall be made of sound Number 1 structural grade spruce and,

- (a) shall be placed in the excavation so that it is parallel to the bottom, or proposed bottom, of the excavation; and
- (b) shall be supported by either cleats secured to the sheathing or posts set on the wale next below it or, if it is the lowest wale, on the bottom of the excavation.
O. Reg. 213/91, s. 238 (5).

239. (1) A support system for the walls of an excavation shall be installed,

EXCAVATION SHORING AND TIMBERING (METRIC SIZES)

Column 1		Column 2	Column 3				Column 4
Excavation Depth	Soil Type	Sheathing	Struts				Wales
			Width of Excavation at Strut Location		Strut Spacing		
			1.8 m to 3.6 m	Up to 1.8 m	Vertical	Horizontal	
3.0 m or less	1	50 mm × 200 mm at 1.2 m o/c	200 mm × 200 mm	150 mm × 150 mm	1.2 m	* 2.4 m	*200 mm × 200 mm
	2	50 mm × 200 mm at 1.2 m o/c	200 mm × 200 mm	150 mm × 150 mm	1.2 m	* 2.4 m	*200 mm × 200 mm
	3	50 mm × 200 mm at 10 mm gap	200 mm × 200 mm	200 mm × 200 mm	1.2 m	2.4 m	250 mm × 250 mm
	4	75 mm × 200 mm at 10 mm gap	250 mm × 250 mm	200 mm × 200 mm	1.2 m	2.4 m	300 mm × 300 mm
Over 3.0 m to 4.5 m	1	50 mm × 200 mm with 10 mm gap	200 mm × 200 mm	150 mm × 150 mm	1.2 m	2.4 m	200 mm × 200 mm
	2	50 mm × 200 mm with 10 mm gap	200 mm × 200 mm	200 mm × 200 mm	1.2 m	2.4 m	250 mm × 250 mm
	3	50 mm × 200 mm with 10 mm gap	250 mm × 250 mm	250 mm × 250 mm	1.2 m	2.4 m	250 mm × 250 mm
Over 3.0 m to 4.0 m	4	75 mm × 200 mm with 10 mm gap	300 mm × 300 mm	300 mm × 300 mm	1.2 m	2.4 m	300 mm × 300 mm
Over 4.5 m to 6.0 m	1	50 mm × 200 mm with 10 mm gap	200 mm × 200 mm	200 mm × 200 mm	1.2 m	2.4 m	200 mm × 200 mm
	2	50 mm × 200 mm with 10 mm gap	250 mm × 250 mm	250 mm × 250 mm	1.2 m	2.4 m	250 mm × 250 mm
	3	50 mm × 200 mm with 10 mm gap	300 mm × 300 mm	300 mm × 300 mm	1.2 m	2.4 m	300 mm × 300 mm

* Note: For excavations to 3 m deep in soil types 1 and 2, the wales can be omitted if the struts are used at 1.2 m horizontal spacings. O. Reg. 213/91, s. 238, Table; O. Reg. 631/94 s. 9.

- (a) progressively in an excavation in Type 1, 2 or 3 soil; and
- (b) in advance of an excavation in Type 4 soil, if practicable. O. Reg. 213/91, s. 239 (1).

(2) A support system for the walls of an excavation shall provide continuous support for it. O. Reg. 213/91, s. 239 (2).

(3) No support system for the walls of an excavation shall be removed until immediately before the excavation is backfilled. O. Reg. 213/91, s. 239 (3).

(4) A competent person shall supervise the removal of a support system for the walls of an excavation. O. Reg. 213/91, s. 239 (4).

240. If a support system is used for the walls of an excavation, a ladder for access to or egress from the excavation shall be placed within the area protected by the support system. O. Reg. 213/91, s. 240.

241. (1) A support system for the walls of an excavation shall extend at least 0.3 metres above the top of the excavation unless otherwise permitted or required by this section. O. Reg. 213/91, s. 241 (1).

(2) If an excavation is located where there is vehicular or pedestrian traffic and if the excavation will be covered when work on or in it is not in progress, the support system for the walls of the excavation shall extend at least to the top of the excavation. O. Reg. 213/91, s. 241 (2).

(3) If the upper portion of the walls of an excavation are sloped for the soil types as described in clauses 234 (2) (e), (f) and (g) and the lower portion of the walls are vertical or near vertical, the walls shall be supported by a support system which extends at least 0.5 metres above the vertical walls. O. Reg. 213/91, s. 241 (3).

242. (1) A metal trench-jack or trench-brace may

be used in place of a timber strut,

(a) if the allowable working load of the trench-jack or trench-brace is equal to or greater than that of the timber strut; and

(b) if the size of the replaced timber strut is shown on the trench-jack or trench-brace.

O. Reg. 213/91, s. 242 (1).

(2) The allowable working load of a metal trench-jack or trench-brace shall be determined by a professional engineer in accordance with good engineering practice and shall be legibly cast or stamped on the trench-jack or trench-brace.

O. Reg. 213/91, s. 242 (2).

(3) No metal trench-jack or trench-brace shall be extended beyond the length used to establish its maximum allowable working load. O. Reg. 213/91, s. 242 (3).

(4) Every metal trench-jack or trench-brace, when it is used,

(a) shall be placed against the wales in such a way that the load from the wales is applied axially to the trench-jack or trench-brace; and

(b) shall be adequately supported so that it does not move out of position. O. Reg. 213/91, s. 242 (4).

REVIEW QUIZ

Background

- Are there regulations which set out requirements for trenching projects?
Yes No
- The major cause of fatalities in the trenching industry is _____.
- List three causes of lost-time injuries in the trenching industry.
1 _____
2 _____
3 _____
- Which diagram best illustrates a trench?
A or B

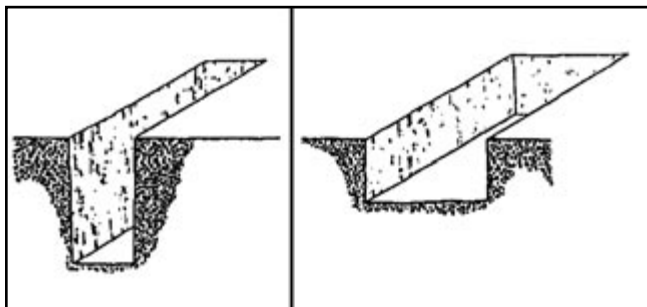

Causes of Cave-ins

- List three causes of cave-ins.
1 _____
2 _____
3 _____
- List three sources of vibration.
1 _____
2 _____
3 _____
- Trench wall stability will change as the trench is exposed to the weather.
True False

- Previously excavated soil, such as that found around existing utilities or used for backfill, is usually less stable.
True False
- Surcharge puts additional pressure on trench walls.
True False

Protection Against Cave-ins.

- The basic methods of protecting workers from cave-ins are:

- The angle of slope for trench walls depends on conditions.
True False
- Which illustration shows the minimum sloping requirements for an unprotected trench in good soil conditions?

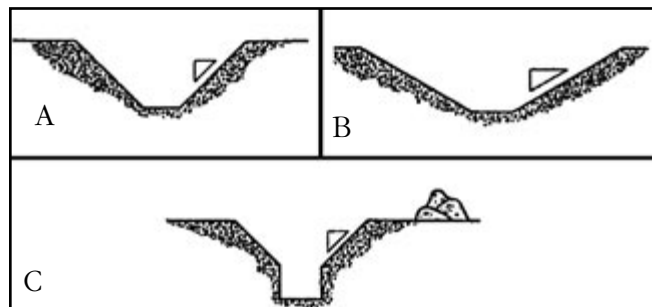

- Trench boxes are usually not intended to support the trench walls.
True False
- The major advantage of hydraulic shoring is that workers can install it without having to enter the trench.
True False

- 6. Dimensions and components of timber shoring change according to soil conditions and the depth of the trench.
True False
- 7. List two components of timber shoring that should always be inspected.
1 _____
2 _____
- 8. Ladders must be placed within the area protected by the shoring or trench box.
True False
- 9. What sign on the ground surface next to the trench would indicate that the trench wall is becoming less stable?

Other Hazards and Safeguards

- 1. List three hazards, other than cave-in, that can occur on trenching projects.
1 _____
2 _____
3 _____
- 2. Underground utilities should first be located by the utility company, then exposed by hand digging before using excavation equipment.
True False
- 3. Workers should stay well back from machines operating near overhead powerlines.
True False

- 4. What should you do if the machine strikes overhead powerlines?
a. Operator _____

b. Worker _____

- 5. What is the main injury likely to result during materials handling? _____

- 6. Workers on foot may be injured or killed by equipment backing up.
True False
- 7. List three ground rules for signallers.
1 _____
2 _____
3 _____
- 8. List three ground rules for personnel working near operating vehicles and heavy equipment.
1 _____
2 _____
3 _____
- 9. Regulations for traffic control require that Traffic Control Persons (TCPs) be given instruction in a language they understand.
True False
- 10. A manhole is a confined space.
True False



About IHSA

IHSA's vision is the elimination of all workplace injuries, illnesses, and fatalities within our member firms.

We engage with our member firms, workers, and other stakeholders to help them continuously improve their health and safety performance. We do this by providing effective and innovative sector-specific programs, products, and services.

We offer

- Training programs
- Consulting services
- Health and safety audits
- Publications and e-news
- Posters and stickers
- Reference material
- A resource-rich website.

Find out what we can do for you at www.ihsa.ca

Infrastructure Health & Safety Association (IHSA)

5110 Creekbank Road, Suite 400
Mississauga, Ontario L4W 0A1 Canada
Tel: 1-800-263-5024 • Fax: 905-625-8998
www.ihsa.ca